

【Wiring description diagram】

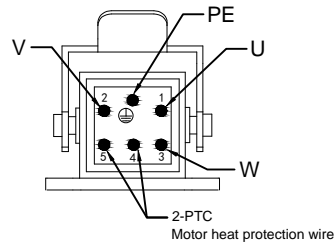

PTC single-core thermistor parameter

DC power supply	Maximum DC25V/100mA
-20~25℃	≤100Ω
≤90℃	≤250Ω
105℃	≤550Ω
110℃	Rated operating temperature
115℃	≥1330Ω
≥125℃	≥4KΩ
≤160℃	Maximum storage temperature

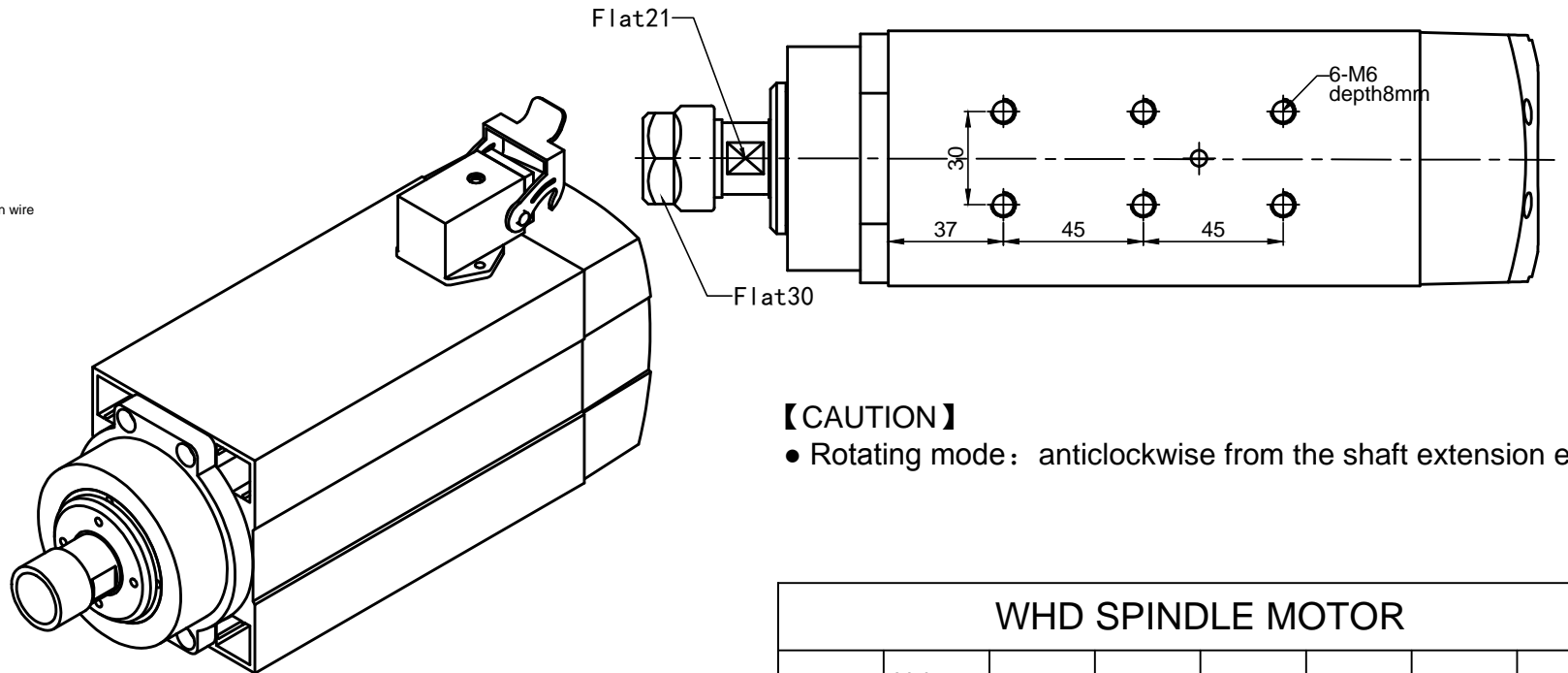

【CAUTION】

- Rotating mode: anticlockwise from the shaft extension end

WHD SPINDLE MOTOR

Power	Voltage	Current	Shaft	Frequency	Speed	Cool	Weight
1.5KW	220V	5.8A	ER20	300Hz	18000RPM	Air	6.4KG