

STF47-110B-1.5-ER20-JXH

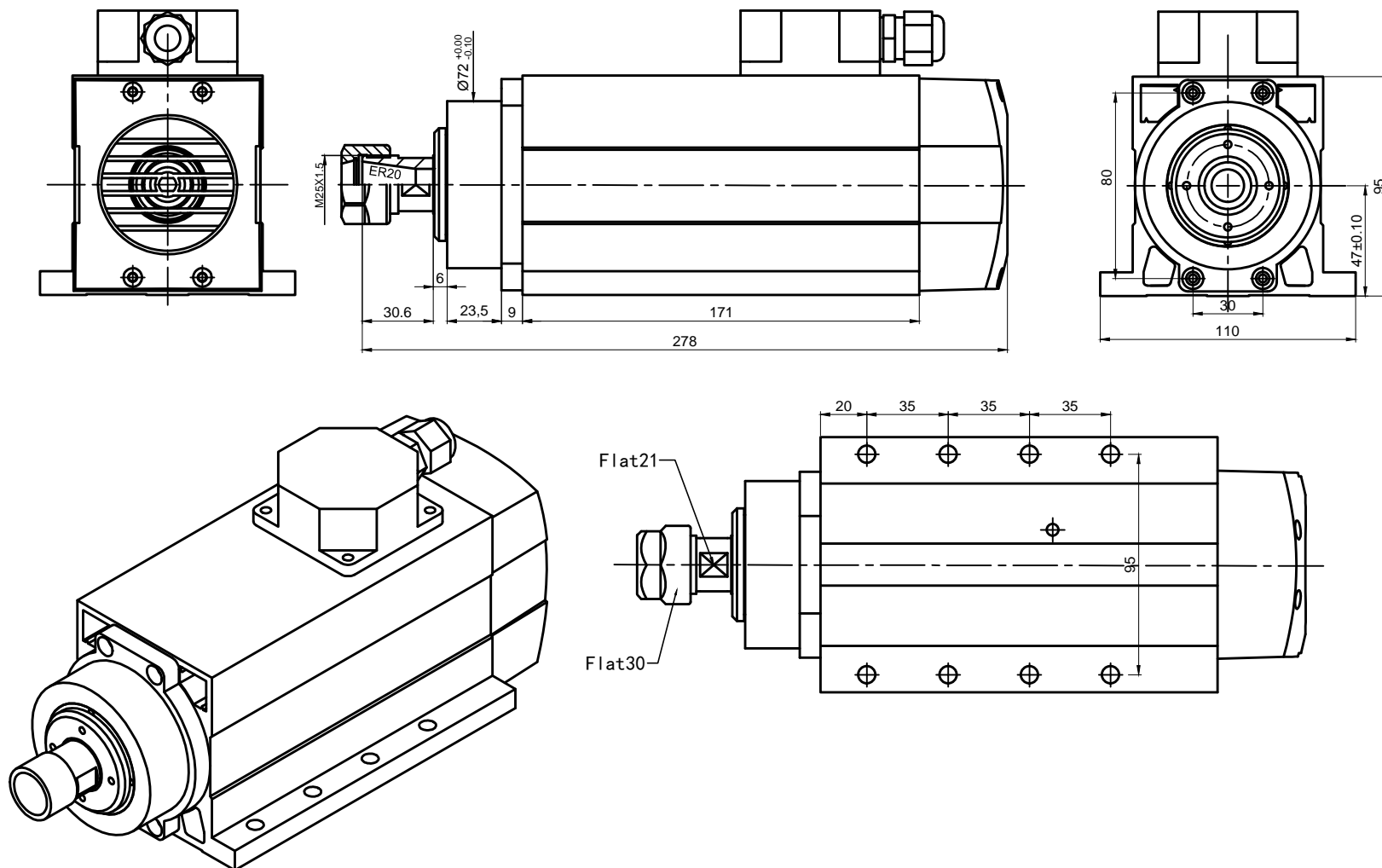

【CAUTION】

- Rotating mode: anticlockwise from the shaft extension end

WHD SPINDLE MOTOR							
Power	Voltage	Current	Shaft	Frequency	Speed	Cool	Weight
1.5KW	380V	3.2A	ER20	300Hz	18000RPM	Air	6.4KG